

816NT Series

OS&Y UL/FM Resilient Seated Gate Valve 2 1/2"-12", Flanged Ends, No Tap

SPECIFICATIONS

- COMPLIES WITH AWWA C515 STANDARD
- HEAVY DUTY HANDWHEEL AND ATTACHMENT NUT
- HIGH QUALITY GRAPHITE STEM SEAL
- NO TAP/PLUG ON BODY
- FLANGES TO ANSI B16.1 CLASS 125 (OTHER FLANGE TYPES AVAILABLE ON REQUEST)
- UL LISTED AND FM APPROVED
- CERTIFIED TO NSF/ANSI 61 & 372

WORKING PRESSURE

- 300 PSI

WORKING TEMPERATURE

- 33°F TO 170°F

CORROSION PROTECTION

- FUSION BONDED EPOXY COATED INTERIOR AND EXTERIOR TO AWWA C550 STANDARD

INSTALLATION

- VALVES INSTALLED IN HORIZONTAL PIPING SYSTEMS SHOULD HAVE THE STEMS ORIENTED VERTICALLY
- VALVES INSTALLED IN VERTICAL PIPING SYSTEMS SHOULD HAVE THE STEMS ORIENTED HORIZONTALLY

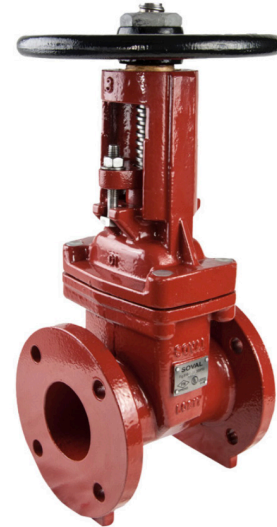

COMPONENTS

NO.	PART NAME	MATERIAL	ASTM SPECIFICATIONS
1	BODY	DUCTILE IRON	ASTM A536 65-45-12
2	WEDGE	DUCTILE IRON	EPDM ENCAPSULATED
3	WEDGE NUT	STAINLESS STEEL	AISI 304
4	PIN	STAINLESS STEEL	AISI 420
5	O-RING	RUBBER	EPDM
6	GASKET	RUBBER	EPDM
7	STEM	STAINLESS STEEL	AISI 304
8	BONNET	DUCTILE IRON	ASTM A536 65-45-12
9	PACKING	GRAPHITE	
10	GLAND	DUCTILE IRON	ASTM A536 65-45-12
11	YOKE NUT	BRONZE	ASTM C95200
12	WASHER	BRASS	
13	HANDWHEEL	DUCTILE IRON	ASTM A536 65-45-12
14	HANDWHEEL NUT	DUCTILE IRON	ASTM A536 65-45-12
15	BOLTS	STAINLESS STEEL	A2-70
16	NUTS	STAINLESS STEEL	A4-70
17	WASHERS	STAINLESS STEEL	AISI 304
18	BONNET BOLTS	CARBON STEEL	GR8.8 ZINC PLATED

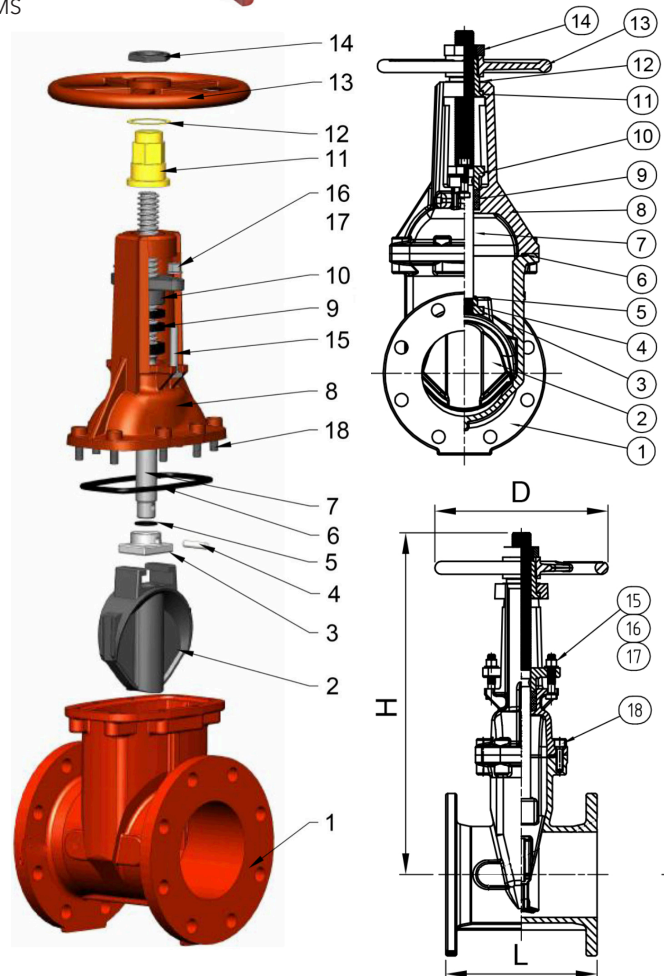

DIMENSIONS

	(INCHES)							
SIZE	2 1/2"	3"	4"	5"	6"	8"	10"	12"
L	7 1/2	8	9	10	10 1/2	11 1/2	13	14
H (OPEN)	16 5/8	18 7/8	21 5/8	25 4/5	29 1/8	36 5/8	44 1/2	52
H (CLOSE)	13 3/4	15 3/4	17 3/4	20 7/8	23 1/4	28 3/4	34 3/4	40 1/6
D	7 1/4	10	10	12	12	14	17 1/2	17 1/2