

609-9276NL Series Bugatti Forged Brass Lead-Free Valve C/C, Large Steel Handle

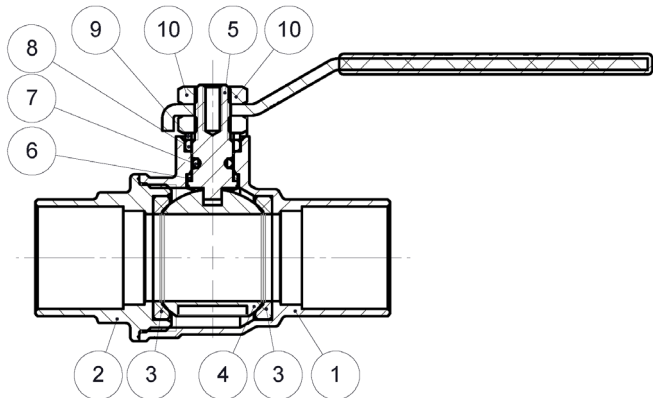

- ASSEMBLY IN RIGID PIPE SYSTEM
- KV: FLOW RATE COEFFICIENT M³/H
- DIRECTION OF FLOW: BOTH DIRECTIONS
- TEMPERATURE RANGE: -4°F TO 248°F
- MAXIMUM PRESSURE:
 - 600 WOG (WATER, OIL, GAS)
 - 70 PSI LP GAS
 - 150 WSP (WORKING STEAM PRESSURE)
- UL / FM / CSA / NSF
- LEAD-FREE

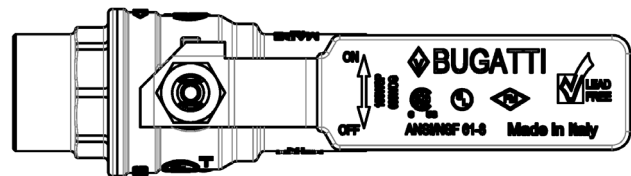
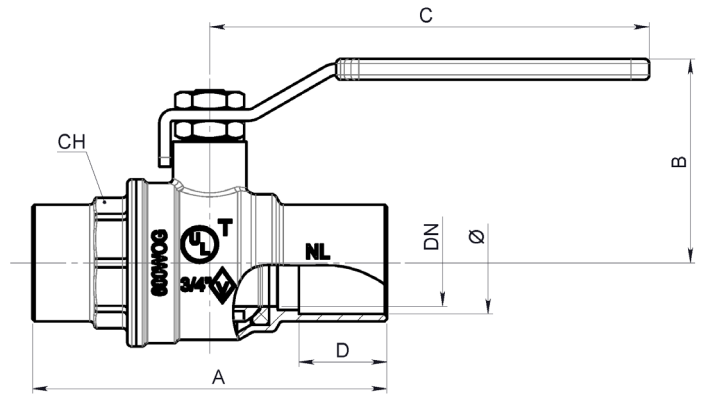

SPECIFICATION

| | |
|-------------|-----------------------------------|
| THREAD ENDS | ASME B 16.18-2001 |
| ORIFICE | 0.57 TO 1.96 |
| ACTUATOR | 90° ROTATION WITH MECHANICAL STOP |
| OPERATOR | STEEL HANDLE (LARGE) |

COMPONENTS

| NO. | PART NAME | MATERIAL | QTY |
|-----|----------------|----------------------|-----|
| 1 | BODY | CW510L, ANNEALING | 1 |
| 2 | END CONNECTION | CW510L, ANNEALING | 1 |
| 3 | BALL SEAL | PTFE | 2 |
| 4 | BALL | CW510L, NI+CR PLATED | 1 |
| 5 | STEM | CW614N | 1 |
| 6 | LOWER SEAL | PTFE | 1 |
| 7 | O-RING | NBR70SH | 1 |
| 8 | UPPER SEAL | PTFE | 1 |
| 9 | BRASS RING | CW614N | 1 |
| 10 | NUT | STEEL, ZINC PLATED | 2 |
| 11 | HANDLE | STEEL | 1 |

DIMENSIONS

(INCHES)

| SIZE | Ø | DN | A | B | C | D | CH |
|--------|-------|------|------|------|------|------|------|
| 1/2" | 0.630 | 0.57 | 2.25 | 1.57 | 3.35 | 0.42 | 0.79 |
| 3/4" | 0.866 | 0.75 | 3.05 | 1.77 | 3.80 | 0.61 | 1.06 |
| 1" | 1.102 | 0.94 | 3.68 | 2.03 | 3.80 | 0.73 | 1.34 |
| 1 1/4" | 1.377 | 1.24 | 4.18 | 2.32 | 4.72 | 0.91 | 1.61 |
| 1 1/2" | 1.610 | 1.49 | 4.96 | 2.60 | 4.72 | 1.06 | 1.89 |
| 8" | 2.125 | 1.96 | 5.87 | 3.27 | 6.38 | 1.26 | 2.40 |